

# IntraPac Metal Tubes

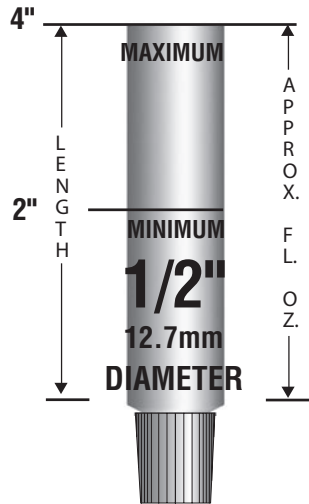

This drawing indicates diameter size and minimum and maximum lengths for various capacities. The gram weights and fluid ounces for each tube are based on a specific gravity of 1.0.

Please note that these tables are intended only as a guide. Product formulation, type of fill, and filling machinery used must be considered to determine exact capacity. Because of these factors IntraPac cannot accept responsibility for inaccuracies resulting from the use of these tables. The capacities shown are based on a standard crimping or sealing allowance. Before deciding the final tube dimension, test filling of the actual product should be made. This will help ensure the tube sizing is appropriate.

IntraPac reserves the right to change or modify the design of its products without any obligation to provide notification of change or intent to change.

08.02 Copyright © 2004 IntraPac All Rights Reserved.

LENGTH	APPROX GRAMS	APPROX VOLUME FLUID OUNCES
2"	3.2	0.108
4"	9.6	0.325

NECK SIZE	ORIFICE SIZE
#10	0.165 / Blind
#12	0.180 / Blind
Eye Tip	0.060
Tamper Eye Tip	0.053



For more information visit us at [www.intrapacgroup.com](http://www.intrapacgroup.com)