

IntraPac Laminate Tubes

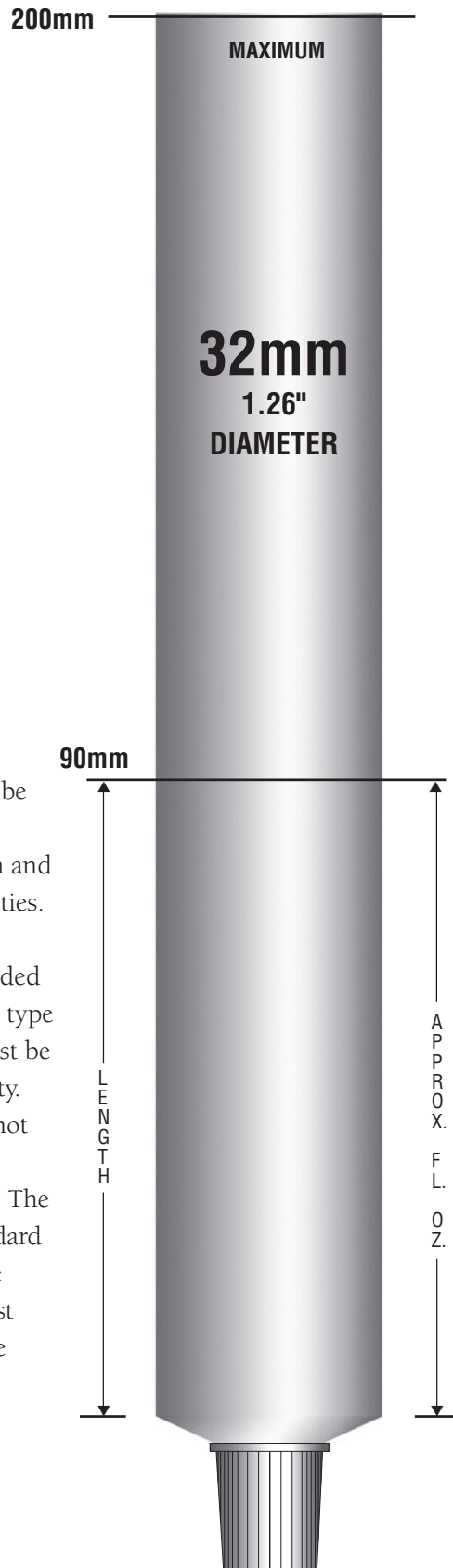

IntraPac offers a complete range of tube sizes and capacities. This drawing indicates diameter size and minimum and maximum lengths for various capacities.

Please note that these tables are intended only as a guide. Product formulation, type of fill, and filling machinery used must be considered to determine exact capacity. Because of these factors IntraPac cannot accept responsibility for inaccuracies resulting from the use of these tables. The capacities shown are based on a standard crimping or sealing allowance. Before deciding the final tube dimension, test filling of the actual product should be made. This will help ensure the tube sizing is appropriate.

LENGTH	APPROX GRAMS	APPROX VOLUME FLUID OUNCES
90mm	52.44	1.78
200mm	137.56	4.66

NECK SIZE	ORIFICE SIZE
13.1	0.320
M14	0.320

IntraPac reserves the right to change or modify the design of its products without any obligation to provide notification of change or intent to change.



For more information visit us at www.intrapacgroup.com